



FREE STANDING GAS FRYER - FOUR TUBE - NATURAL GAS

Model	Product ID	Gas	Capacity
KF4-N	919596	Natural	50 LB

STANDARD FEATURES

- Peened stainless steel tank w/ smoothed out welds
- Stainless steel front, top ledge & header
- 1 1/4" ball type - full port drain
- Cool zone in fry tank
- Built in flue deflector
- Efficient (30,000) BTU heat exchange tubes w/ high heat baffles
- Double rod stainless steel basket hanger
- Stainless steel door w/ door stabilizer
- Smooth finish, high grade G90 galvanized sides & back
- (2) nickel-chrome wire mesh fry baskets red plastic coated handles
- Invensys thermostat - 200°F to 400°F
- Auto reset high limit
- 6" adjustable legs
- Full foam zone
- Heavy construction

ACCESSORIES

- Non-adjustable casters
- Stainless steel tank covers
- Flame guard

WARRANTY

Kintera Gas Cooking Equipment is warranted to be free from defects in material and workmanship under normal use and service for a period of 1 year from the date of original purchase.



SPECIFICATIONS

The fry tank is a peened all stainless steel tank with an efficient high heat baffle system, cool zone and a 1 1/4" full port drain valve. The front and door are stainless steel. Two fry baskets are included with red plastic coated handles. Millivolt thermostat allows a temperature range of 200°F to 400°F. A back-up safety hi-limit control shuts the fryer down if shortening exceeds the maximum temperature. The thermostat, gas valve and hi-limit are Invensys/Robertshaw parts.

IMPORTANT INFORMATION

- An internal pressure regulator is provided with fryer. No external pressure regulator is required.
- 3/4" NPT (19mm) rear gas connection.
- This fryer is **not field convertible**, please order gas specific.
- Requires a 6" clearance on the sides and rear to combustible surfaces.
- Requires a 16" clearance to open top burner units or any open flames.

Model	Product ID	Width		Depth		Overall Height	Working Height				Gas Connection		Total BTU/HR	Crated Weight
		A	B	C	D	E + G	E	F	G	H	I			
KF4-N	919596	15 1/2"	14"	30 3/10"	14"	53 1/5"	47 1/5"	34 7/10"	6"	4 17/32"	6 5/8"	120,000	183 lbs	

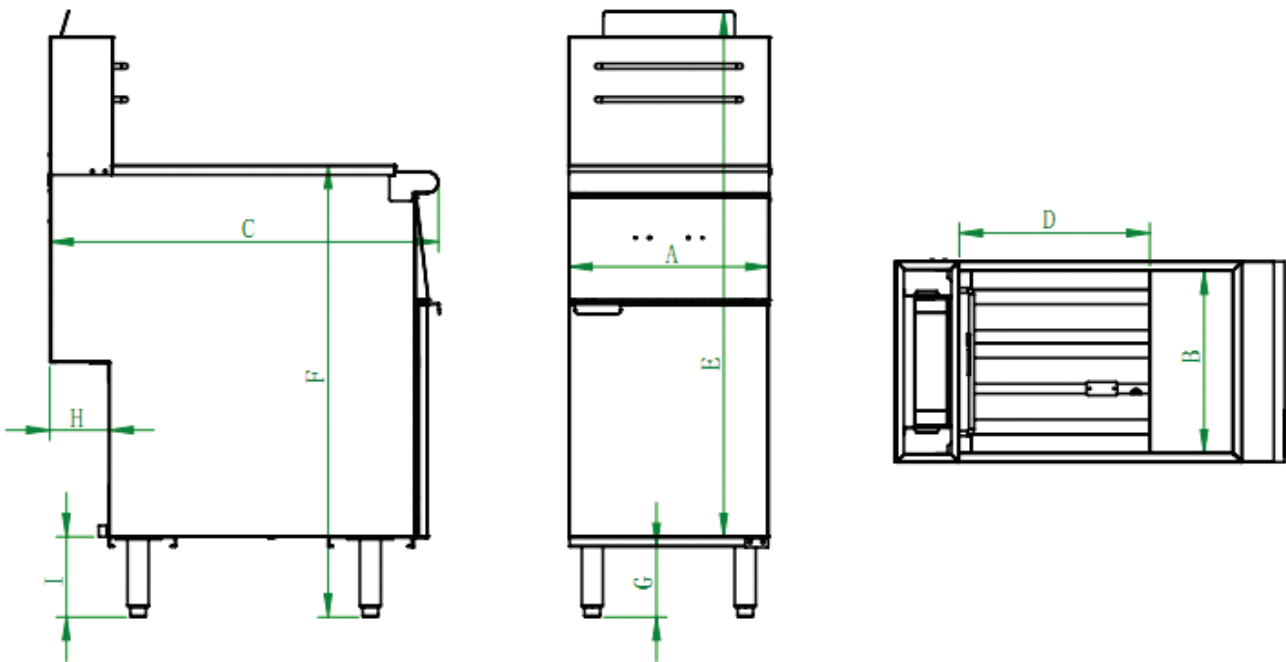

Model	Product ID	Burners	Gas Types	Manifold Pressure	Number of Heat Tubes	Rate Rate BTU/HR	Total BTU/HR	Orifice Size
KF4-N	919596	Main	Natural	4" W.C.	4	30,000	120,000	#39

* Minimum supply pressure is 4" W.C. for natural gas and 10" W.C. for propane.

** Orifice sizes are for units installed at altitudes between 0 and 2,000 feet above sea level.